

REVISION HISTORY				
REV	DESCRIPTION	DESIGNER	CREATION DA	CHECKED BY
1	INITIAL RELEASE	M.MAKIN	17/05/2017	

**NOTES:**

- ACCESS POINT 1 : FIRST CHAMBER -  $\phi 600$
- ACCESS POINT 2 : BY PASS CHAMBER -  $\phi 600$
- ACCESS POINT 3 : COALESCER CHAMBER - 1200 X 600
- ACCESS POINT 4 : AUTO CLOSURE VALVE CHAMBER - 900 X 600

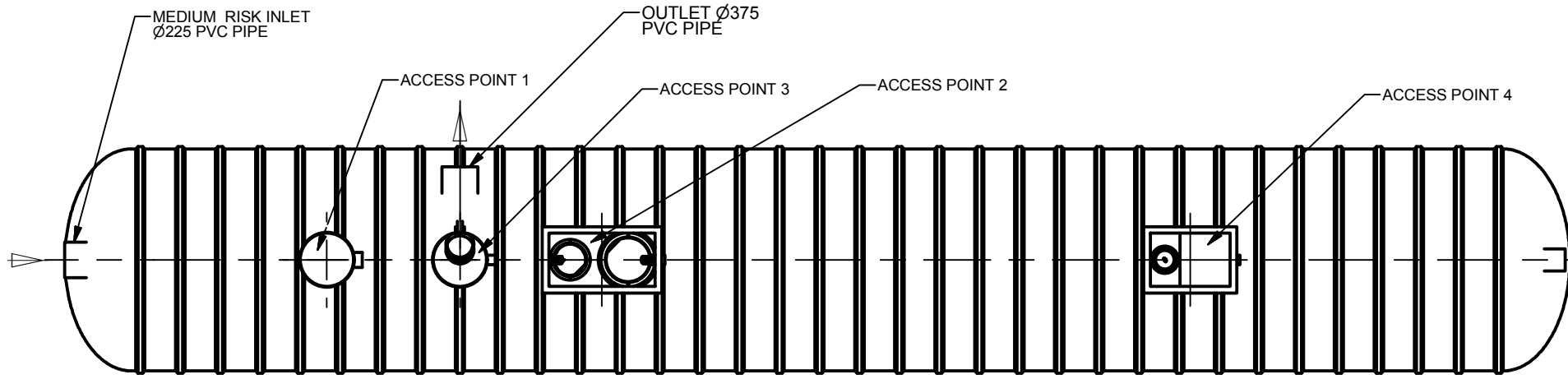

**PLAN VIEW**

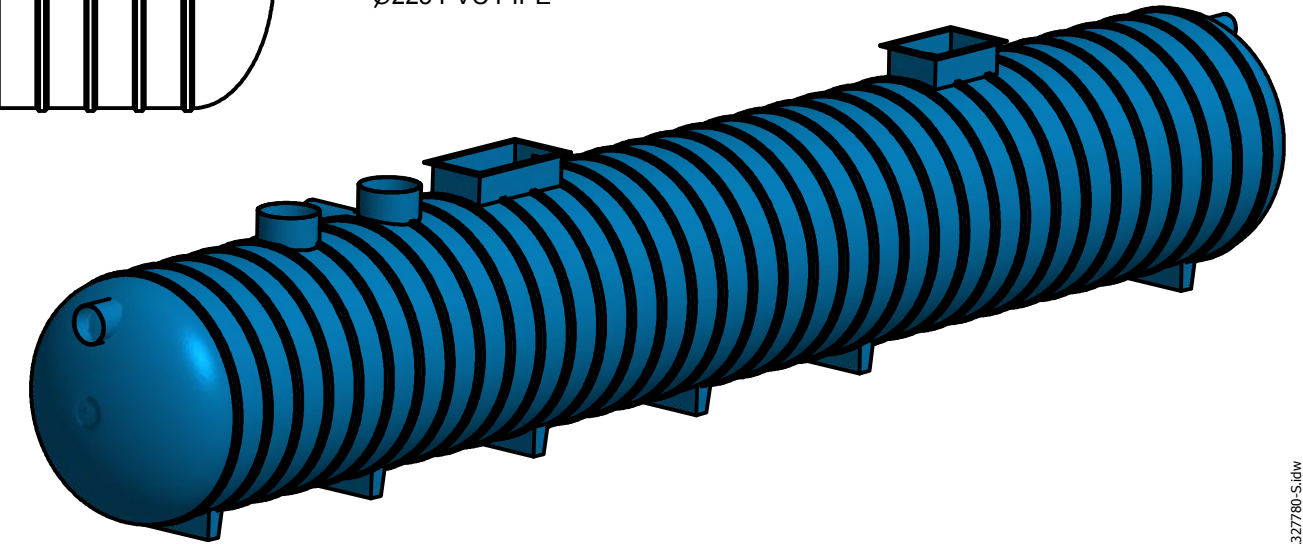

**ISOMETRIC VIEW**

Site Level Confirmation	
Finished Surface Level (FSL) RL:	
Access Cover Thickness	mm
Inlet Invert Level RL:	
Outlet Invert Level RL:	
Company:	
Name:	
Date:	

APPROVED.....

NAME.....

SIGNED.....

DATE...../...../.....

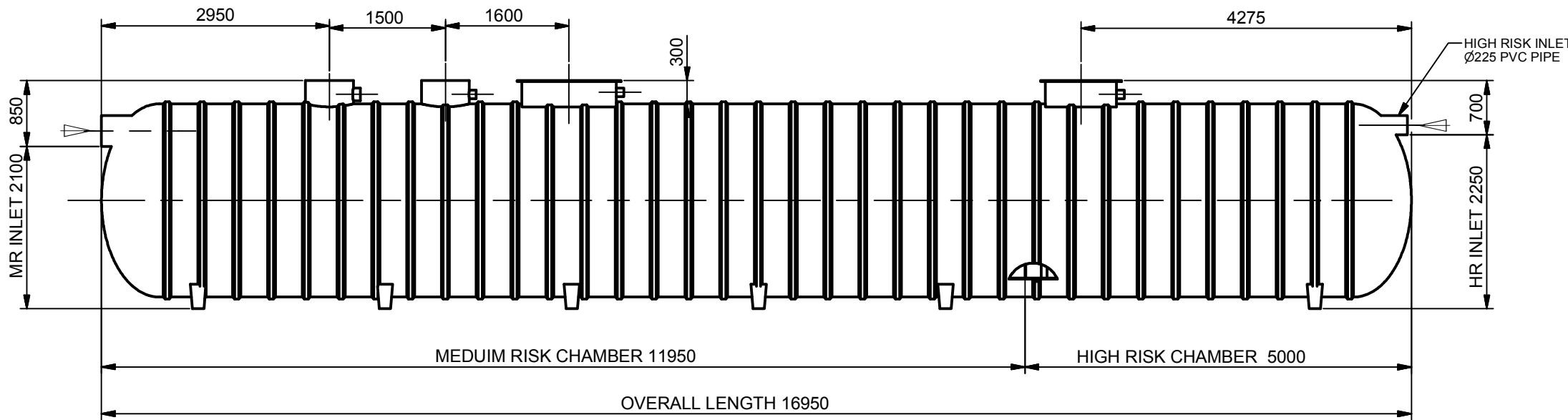

**ELEVATION VIEW**

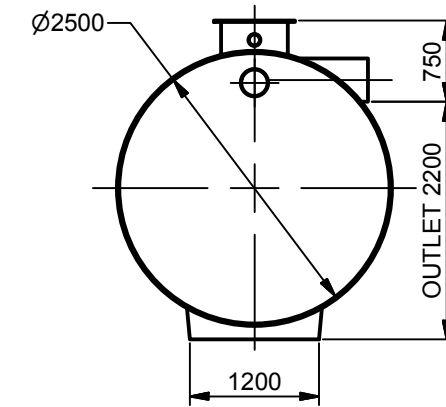

**SIDE VIEW**

**ISSUE FOR APPROVAL**  
NOT FOR CONSTRUCTION

TOLERANCE: ALL DIMENSIONS 10mm UNLESS OTHERWISE STATED.

CLIENT:

DISTRIBUTOR :

CONFIDENTIAL - The drawings must not be disclosed to any third parties without written permission from SPEL Environmental Sydney. Unauthorised disclosure may result in prosecution.  
 © SPEL Environmental - This drawing is the property of SPEL Environmental ABN: 83 151 832 629 and is subject to return on demand. It is submitted for the use only in connection with the proposal and contracts of SPEL Environmental with the expressed conditions that it is not to be reproduced or copied in any form. This data must only be used in accordance with our standard terms and conditions.  
 © Copyright  
 SPEL Environmental accepts no responsibility for any loss or damage resulting from any person acting on this information. The details and dimensions contained in this document may change, please check with SPEL Environmental for confirmation of current specifications.

Drawn	Date
M.MAKIN	17/05/2017
Check	Date
Verified	Date
Approved	Date
Request No.	
RN2790	

**SPEL**  
ENVIRONMENTAL  
INTEGRATED WATER SOLUTIONS

100 Silverwater Road Silverwater NSW 2128  
PH: 1300 773 500 | E: sales@spel.com.au  
www.spel.com.au

PROJECT :			
TITLE			
SPEL TRICEPTOR T.400/700/40.C1.3C.D.225 GENERAL ARRANGEMENT			
SCALE	N.T.S	SIZE	A3
SHEET	1	REV	1
CUSTOMER CODE :		DWG No.	
		SP17-TR327780-S	

D:\Vault\Working Folder\Designs\SPEL\PRODUCTS\TRICEPTOR\STANDARD\TRICEPTOR - ID2480 - T.400-700.040.S.C1.3C.STANDARD\SP17-TR327780-S.dwg